

# JBC

[www.jbctools.com](http://www.jbctools.com)



## Hot Air Station without extractor desk

Ref. JT-QD

## Packing List

The following items should be included:

**JTE Control Unit** ..... 1 unit  
 Ref. JTE-1D (120V)  
 JTE-2D (230V)  
 JTE-9D (100V)



**Heater hose set** ..... 1 unit  
 Ref. JT-T1A (100V / 120V)  
 JT-T2A (230V)



**Stand** ..... 1 unit  
 Ref. JT-SD



**Nozzles** ..... 1 unit  
 Ref. JN2015  
 JN2012  
 JN2020



**Power Cord** ..... 1 unit  
 Ref. 0009417 (100V/120V)  
 0009401 (230V)



**Manual** ..... 1 unit  
 Ref. 0016476



## Features

### USB-B connector

Update the station software from the JBC website

Activates the suction pump



Heating element

**Heater Hose set**  
Ref. JT-T1A (100V/120V)  
JT-T2A (230V)

Hot Air button  
(On / Off)



**Suction Tube**  
Ref. 0932330  
For tripods and extractors

Another connectable tool:  
**Precision Heater hose set**  
Ref: TE-TB

**Stand**  
Ref. JT-SD

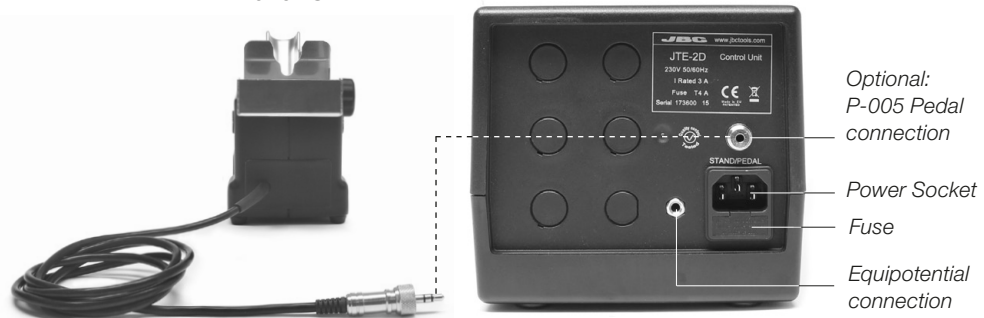

## Adjustable Stand

Adjust the tool holder angle to suit your work position.



## Operation Modes

1. From the main Menu, select the mode to activate the tool depending on the task.

### Stand + Autostart OFF



Press the start/stop button to blow hot air.

### Stand + Autostart ON



The tool automatically starts blowing hot air when lifted from the stand.

### Pedal\*

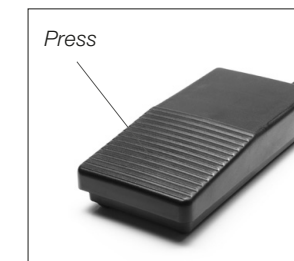

Press the Pedal to blow hot air and release to stop.  
\*The **P-005** Pedal is not supplied with this station. See our website.

2. The tool stops blowing hot air when returned to the stand.



## Quick Nozzle Changer

Changing nozzles quickly and safely.

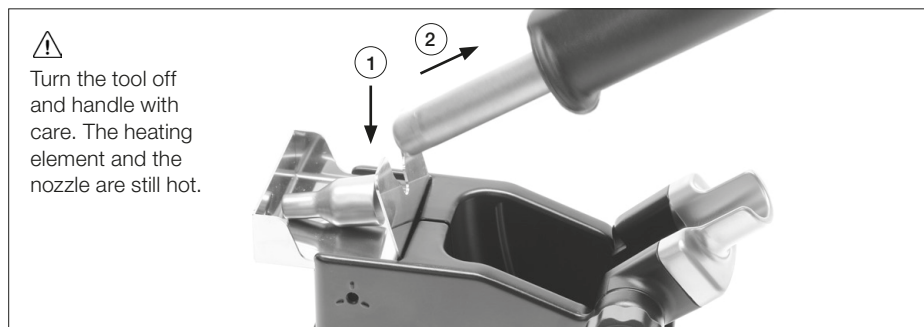

## Compatible Nozzles

The JT-TA works with JT nozzles. Find the model that best suits your soldering needs in [www.jbctools.com](http://www.jbctools.com)

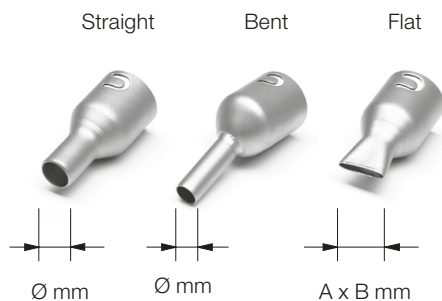

Ref.	Shape	Size
JN2020	Straight	Ø 8mm
JN8417	Straight	Ø 10mm
JN2015	Bent	Ø 4mm
JN2012	Bent	Ø 6mm
JN6633	Bent	Ø 8mm
JN7637	Flat	10 x 2mm
JN7638	Flat	20 x 2mm
JN7639	Flat	30 x 2mm

In case of a loosely fitting nozzle:

1. Push the nozzle tab inwards with a screwdriver or flat-nosed pliers.

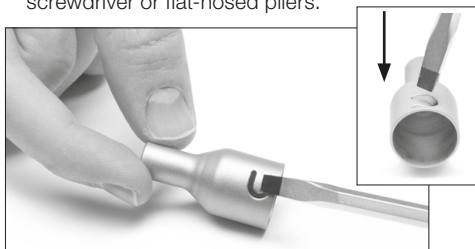

2. Insert the nozzle into the JT-TA Heater again.

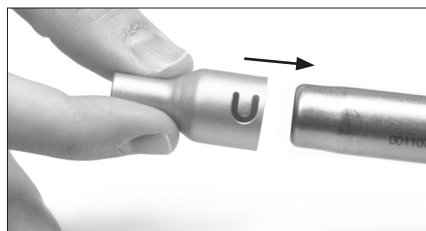

## Operation

### 1. Placing

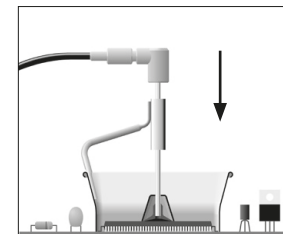

Position the extractor with the appropriate suction cup and press the suction button.

### 2. Heating

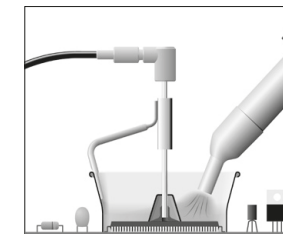

Heat the component.

### 3. Releasing

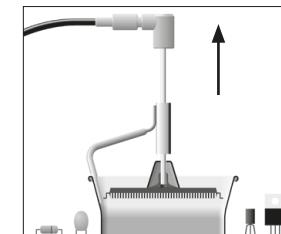

The component lifts off automatically when the solder melts.

## Process Control

### Manual Mode

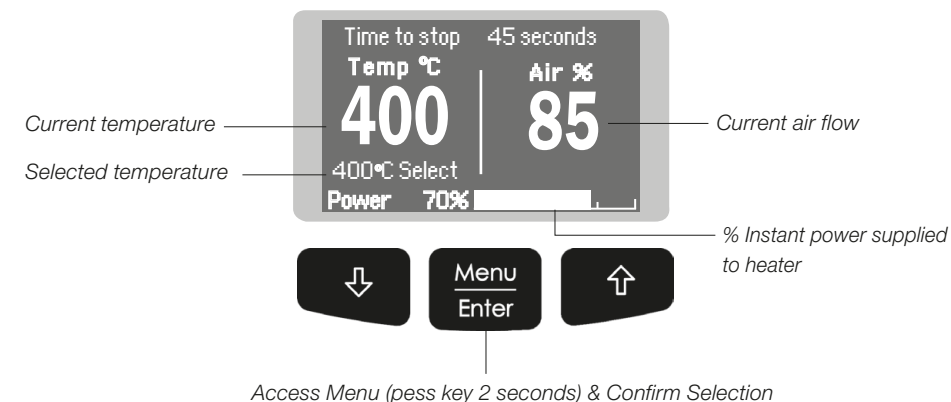

You can switch between operating modes (Manual Mode / Program Mode) by pressing the "increase" and "decrease" keys simultaneously for 2 seconds (Only when programs mode is ON).

## Program Mode

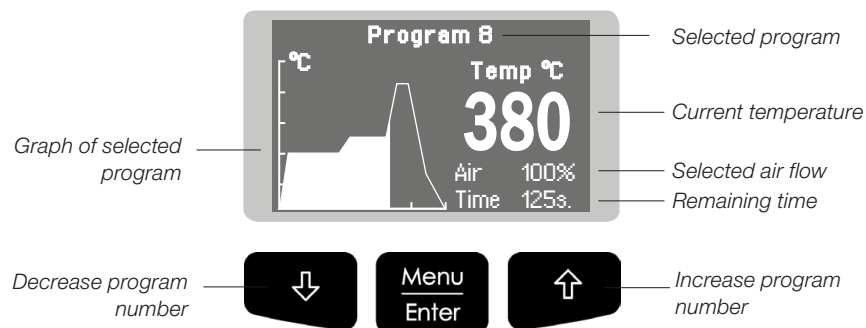

## Program Options

### Edit Program

This option allows you to edit or create a program.

First, you must select the program to edit and then modify the points that make up the program.

Each program is composed of 9 points, each point consisting of 3 parameters:

1. Time (seconds)
2. Temperature (°C / °F)
3. Flow rate (%)

You can delete the last point of the program by selecting "-----" in the time parameter.

It should be taken into account that the regulation range permitted by the station is 150-450°C, whereby it is not possible to create temperature ramps between room temperature (Toff) and 150°C.

The station can store up to 25 temperature programs.

The first three programs are edited by JBC as an example.

### Copy Program

This option allows you to copy a program.

You must select the program source and its destination (where it will be copied).

### Delete Program

This option will allow you to delete a previously selected program.

## Menu Screen

Original PIN: 0105

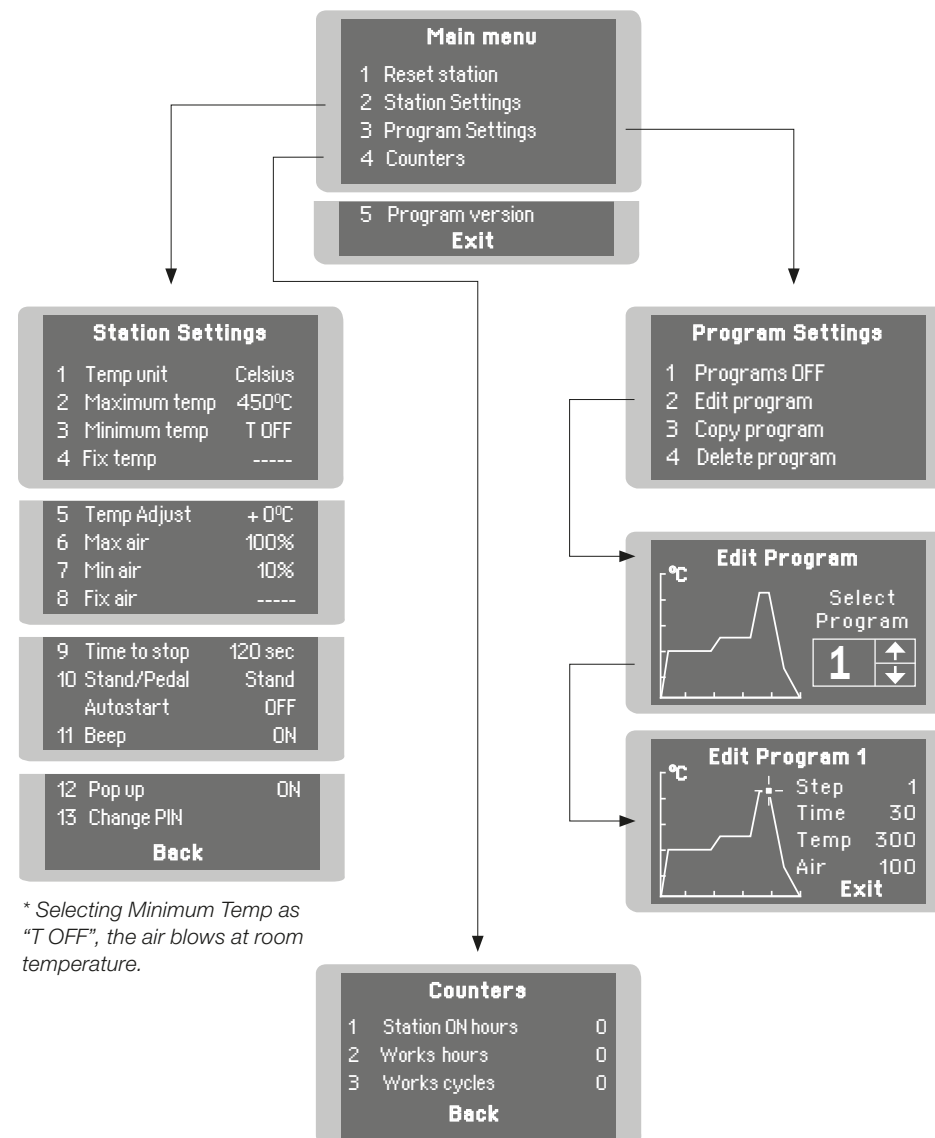

\* Selecting Minimum Temp as "T OFF", the air blows at room temperature.

## Replacing the Heating Element

Only perform this operation when the element is cold and the unit is disconnected from the mains.

1. Loosen the screw.
2. Pull the heating element away from the handle.
3. Connect the new heating element, ensuring its pushed all the way in.
4. Tighten the screw.

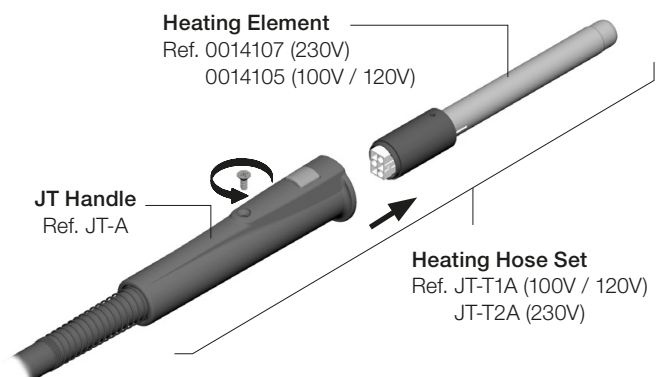

## Changing the JT-TA Heater Hose Set

1. Ensure that the tool is turned off.
2. Use a spanner to unscrew the connecting nut.
3. The tube end of the new heater must be inserted so that the longitudinal rib fits into the groove.
4. Follow the same steps conversely.



## Hot Air Accessories (not supplied with JT-Q)

Find the model that best suits your soldering needs in [www.jbctools.com](http://www.jbctools.com)

**Protector**



**Tripod**



**Extractor**



**Manual extractor**



**For small components** (fig. 1 and 2).  
We recommend using the protector + tripod.

**For big components** (fig. 3 and 4).  
We recommend using the extractor.

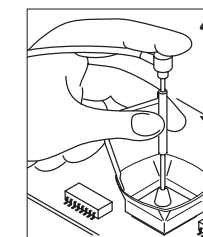
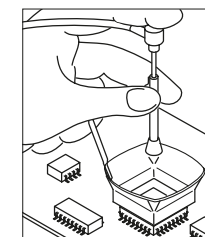
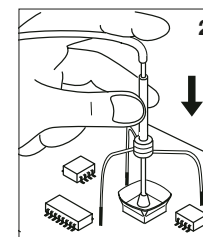
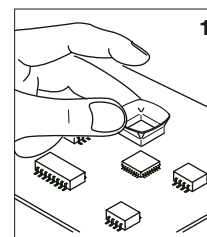

## Extractor Desk

This accessory lets you quickly switch between different models of extractors and protectors. There are two drawers for storage.

**Extractor desk**  
Ref. 0008752

*Protectors  
and extractors  
not included.*



## Pick & Place

This tool helps you easily place and remove SMDs of any size thanks to the suction system.

**Pick & Place**  
Ref. T260-A



**Bent Needles Set**  
Ref. 0861660



**Straight Needles Set**  
Ref. 0901546



**Suction Cups**  
Ref. 0930110



## Operation

Choose the needle and the suction cup that best fits the component and start working as follows:

Press the button to start/stop the suction

**Pick & Place**  
Ref. T260-A

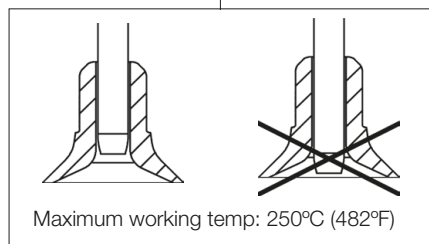
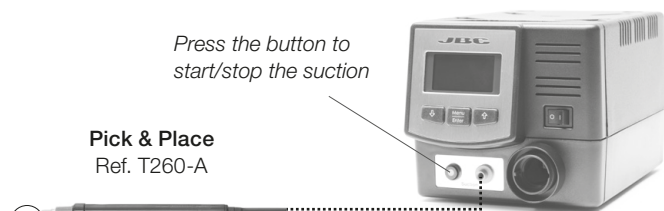

Insert the needle with the appropriate cup for a correct suction process.

You should avoid the needle protruding from the lower part.

### 1. Suction

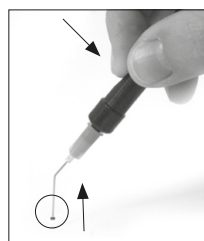

Once the suction is activated, cover the pen hole with your finger and lift off the component.

### 2. Release

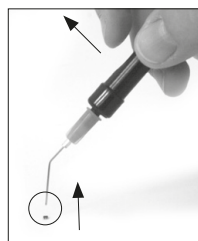

Lift your finger to release the component in the appropriate place.

## Maintenance

Before carrying out maintenance or storage, always allow the equipment to cool.

- Clean the station screen with a glass cleaner or a damp cloth.
- Use a damp cloth to clean the casing and the tool. Alcohol can only be used to clean the metal parts.
- Maintain heating element clean prior to storage in order to avoid its oxidation. Rusty and dirty surfaces reduce heat transfer.
- Periodically check all cables and tubes.
- Replace a blown fuse as follows:

Clean periodically

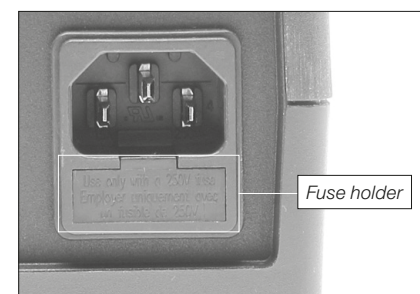

1. Pull off the fuse holder and remove the fuse. If necessary use a tool to lever it off.

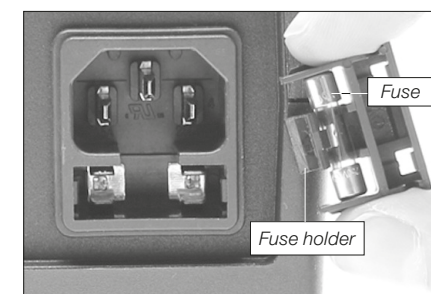

2. Press the new fuse into the fuse holder and replace it in the station.

- Replace any defective or damaged pieces. Use original JBC spare parts only.
- Repairs should only be performed by a JBC authorized technical service.



## Safety



**It is imperative to follow safety guidelines to prevent electric shock, injury, fire or explosion.**

- Do not use the units for any purpose other than soldering or rework. Incorrect use may cause fire.
- The power cord must be plugged into approved bases. Be sure that it is properly grounded before use. When unplugging it, hold the plug, not the wire.
- Do not work on electrically live parts.
- The tool should be placed in the stand when not in use in order to stop blowing hot air. The nozzle, the heating element and the metal part of the stand may still be hot even when the station is turned off. Handle with care, including when adjusting the stand position or changing nozzles.
- Do not leave the appliance unattended when it is on.
- Do not cover the ventilation grills. Heat can cause inflammable products to ignite.
- Use a "non residue" classified flux and avoid contact with skin or eyes to prevent irritation.
- Be careful with the fumes produced when soldering.
- Keep your workplace clean and tidy. Wear appropriate protective glasses and gloves when working to avoid personal harm.
- Utmost care must be taken with liquid tin waste which can cause burns.
- This appliance can be used by children over the age of eight and also persons with reduced physical, sensory or mental capabilities or lack of experience provided that they have been given adequate supervision or instruction concerning use of the appliance and understand the hazards involved. Children must not play with the appliance.
- Maintenance must not be carried out by children unless supervised.

## Specifications

- JT-1QD** 120V 50/60Hz. Input fuse 8A. Rated current: 6A. Control Unit model: **JTE-1D**  
**JT-2QD** 230V 50/60Hz. Input fuse 4A. Rated current: 3A. Control Unit model: **JTE-2D**  
**JT-9QD** 100V 50/60Hz. Input fuse 8A. Rated current: 7A. Control Unit model: **JTE-9D**
- Weight: 6.7 Kg (14.7lb)
  - Dimensions: 148 x 184 x 140
  - Nominal Power: 700W
  - Temperature selection: Room temperature / 150°C to 450°C (300°F to 840°F)  
Cool mode: T Off. Used to blow air at room temperature
  - Ambient Operating Temperature: 10 to 40°C (50-104°F)
  - Air flow regulation: 10-50 SLPM
  - Vacuum: 30% / 228 mmHg / 9 inHg
  - USB connector station-PC
  - P-005 Pedal Connection

Complies with CE standards  
ESD protected housing "skin effect"



**Exploded View**

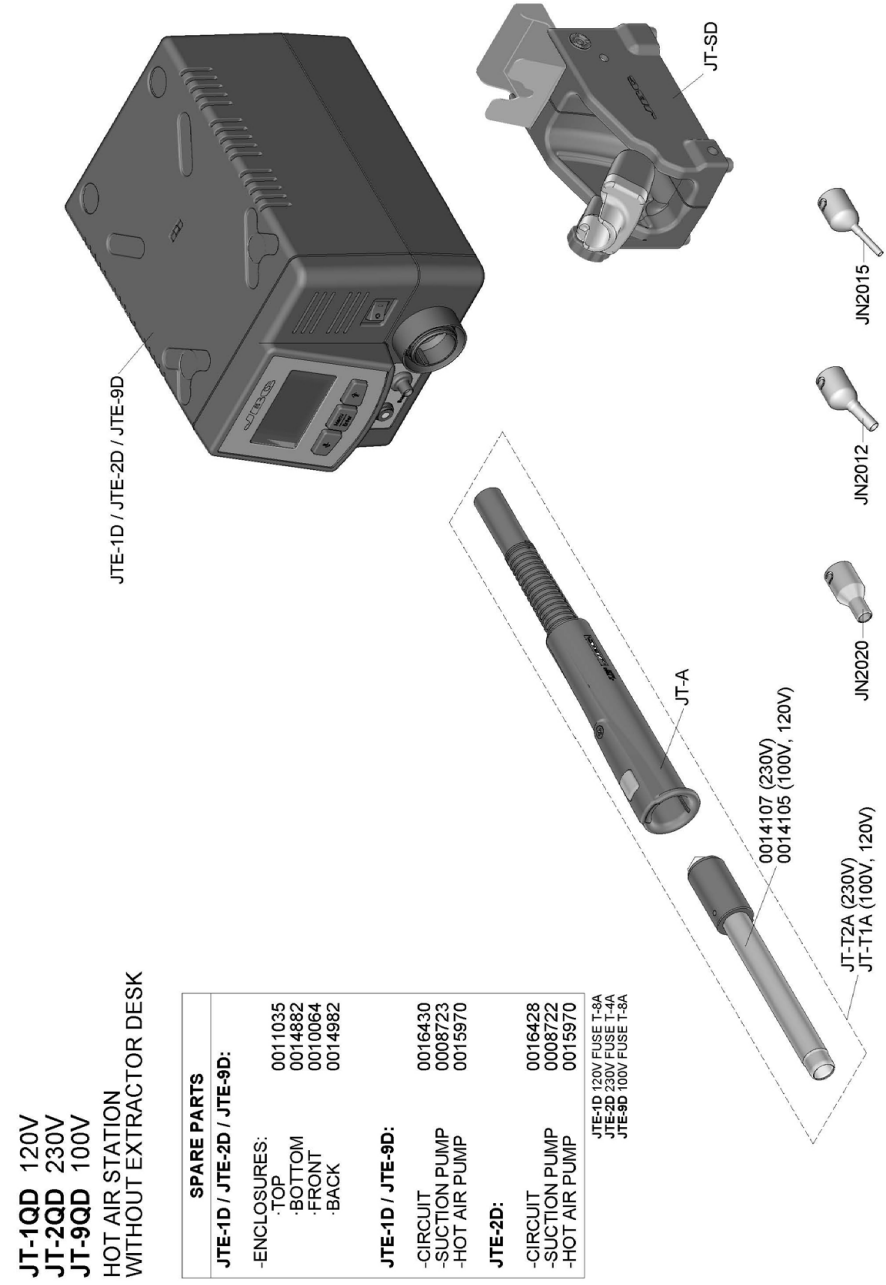

**JT-1QD 120V**  
**JT-2QD 230V**  
**JT-9QD 100V**  
**HOT AIR STATION**  
**WITHOUT EXTRACTOR DESK**

SPARE PARTS	
<b>JTE-1D / JTE-2D / JTE-9D:</b>	
-ENCLOSURES:	0011035
-TOP	0014882
-BOTTOM	0010064
-FRONT	0014982
-BACK	
<b>JTE-1D / JTE-9D:</b>	
-CIRCUIT	0016430
-SUCTION PUMP	0008723
-HOT AIR PUMP	0015970
<b>JTE-2D:</b>	
-CIRCUIT	0016428
-SUCTION PUMP	0008722
-HOT AIR PUMP	0015970
JTE-1D 120V FUSE T-8A	
JTE-2D 230V FUSE T-4A	
JTE-9D 100V FUSE T-8A	

# JBC

---

## Warranty

JBC's 2 year warranty covers this equipment against all manufacturing defects, including the replacement of defective parts and labour.

Warranty does not cover product wear due to use or mis-use.

In order for the warranty to be valid, equipment must be returned, postage paid, to the dealer where it was purchased.



This product should not be thrown in the garbage.

In accordance with the European directive 2002/96/EC, electronic equipment at the end of their life must be collected and returned to an authorized recycling facility.